

CAUTION:

If any questions arise concerning the proper installation or maintenance of our products, please contact Protectoseal or one of our Authorized Representatives.

When installing any Protectoseal device, the legal, corporate and advisory safety regulations and procedures appropriate for the specific installation site must be fully understood and followed.

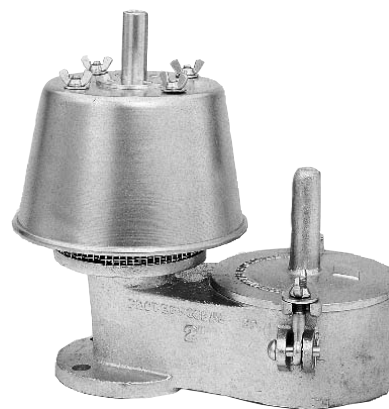

NOTE 1: This vent style includes a removable cover and weather hood. The hood stem guide may be taped to the top of the hood to prevent damage during shipment. This stem guide will be threaded into the tapped hole on top of the hood.

NOTE 2: When pressure or vacuum weights (packed separately if heavy) are included with a unit, the weights should be inspected, properly identified and set aside for later installation. Weights will be stamped with a serial number matching the number on the vent; identification as pressure or vacuum weights; a statement as to the contribution that each weight provides to the total pressure or vacuum setting.

NOTE 3: This vent style allows for spring loaded settings on both the pressure and vacuum sides. It also allows for spring loaded pressure or spring loaded vacuum alone – with the remaining side then being weight loaded. The spring loading capability provides higher pressure or vacuum settings than are available through weight loading. Depending on the size and set point of the vent, very high spring forces may be encountered. Caution must be exercised when working with the spring packages.

Spring Loaded Pressure/Weight Loaded Vacuum

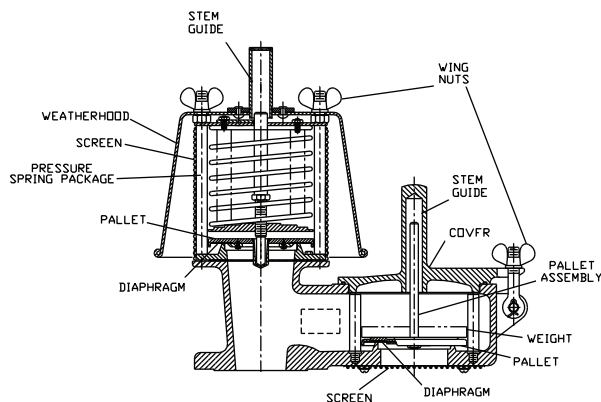

Pressure Spring Package Detail

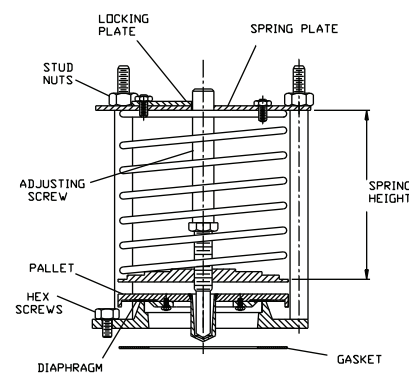

Spring Loaded Vacuum/Weight Loaded Pressure

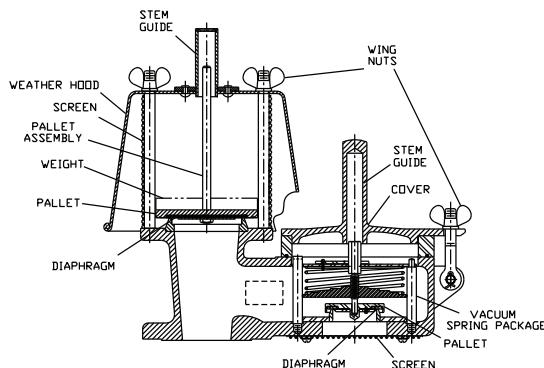

Vacuum Spring Package Detail

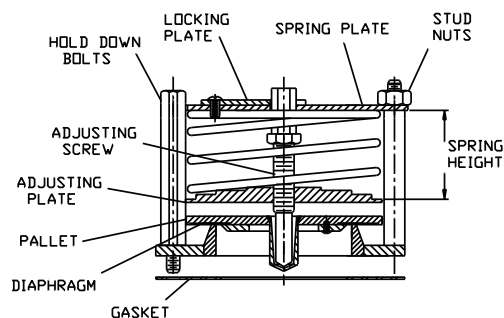

INSTALLATION PROCEDURE:

1. Loosen wing nuts and remove cover and weatherhood.
2. If one of the pallet assemblies is weight loaded, withdraw that pallet assembly from the vent. Remove and discard protective cardboard and tape. The cardboard protects the diaphragms during shipment.
3. Remove all packaging materials. Remove protective flange cover.
4. Check carefully to insure that all packing materials are removed from on or inside the vent housing and from the pallet assemblies.
5. The spring loaded setting is established at the Factory per order specification. No modifications or adjustments to the spring package(s) are required prior to vent installation.
6. Mount the vent to the appropriate tank flange using gaskets compatible with service conditions. Note: For some vent styles, threaded studs that mate with tapped holes in the vent housing flange are provided. For best performance, the vent should be mounted level so that the seating surfaces are no more than 1° off horizontal.
7. Reinstall any weight loaded pallet assembly into its respective opening. Setting weights (if provided) should be installed by engaging the hole in the weight on the appropriate pallet assembly stem. Make sure that weights are properly installed as marked to provide specified set points. Heavy weights may be provided with tapped holes to temporarily attach lifting hardware to facilitate installation. Any such threaded fasteners used during installation must be removed from the weights. Foreign objects will limit the lift capability of the pallet assembly and will reduce rated flow capacity of the vent.
8. Reinstall the cover and weather hood. Note: Make sure that the respective pressure and vacuum pallet assembly stems positively engage the hole in the stem guide in the weatherhood and in the cover. The weight loaded pallet assembly must be free to move upwards, with the pallet stem traveling into the stem guide.
9. Secure cover or hood with wing nuts or nuts.

MAINTENANCE:

Protectoseal recommends that our products be inspected and maintained according to the normal maintenance schedule of the facility. At a minimum, maintenance should be conducted annually. More frequent maintenance may be required, and should be scheduled, for unusual service conditions.

CAUTION: When maintaining any Protectoseal device, the legal, corporate and advisory safety regulations and procedures appropriate for the specific installation site must be fully understood and followed.

CAUTION: Tank vapor space pressure or vacuum should be relieved before any maintenance operations are undertaken.

MAINTENANCE PROCEDURE:

1. Loosen wing nuts and remove cover, weatherhood and screen. No spring forces are involved during the cover or hood removal.
2. Inspect the gasket on the cover. Replace if deteriorated or damaged.
3. Inspect the screens. Replace if deteriorated.
4. Remove any loose dirt or foreign material from the housing interior and exterior. Check inside the stem guide hole of the weather hood and cover and remove any dirt or accumulation of foreign material from these holes.

WEIGHT LOADED SET POINTS (IF APPLICABLE)

1. If one of the sides of the vent is weight loaded, withdraw the pallet assembly and any weights. Set aside for inspection. Note: Identify any weights on the pressure or vacuum pallet assemblies for later reinstallation.
2. Inspect and clean the machined seating surfaces on the weight loaded side of the vent housing with a suitable cleaning fluid. Seats should be free of nicks, marks or accumulations of foreign material.

CAUTION: Do not use a file or other sharp tool to clean the seating surface.

3. Inspect the weight loaded pallet assembly. If pallet is deteriorated or bent, it must be replaced. Inspect the diaphragm material in the weight loaded pallet assembly. The diaphragm must be clean, flat and smooth. If the diaphragm material is deteriorated, it must be replaced. Make sure that all nuts and screws on the pallet assembly are tightened securely.

- Reinstall any weight loaded pressure or vacuum pallet assembly into its respective opening. Setting weights (if provided) should be installed by engaging the hole in the weight on the appropriate pallet assembly stem. Make sure that weights are properly installed as marked to provide specified set points. Heavy weights may be provided with tapped holes to temporarily attach lifting hardware to facilitate installation. Any such threaded fasteners used during installation must be removed from the weights. Foreign objects will limit the lift capability of the pallet assemblies and will reduce rated flow capacity of the vent.

SPRING LOADED SET POINTS

- This vent is designed to include a modular spring package that may be removed in its entirety from the housing. All spring forces are contained by this spring package which can be removed from the housing for inspection or maintenance. The top of the spring package is the spring plate. The bottom of the spring package is the seat flange. If the vent has a spring package on the pressure side, the package is secured to the housing with (4) or (8) hex screws (depending on the size of the vent). If the vent has a spring package on the vacuum side, (4) or (8) slotted or hexagonal shaped hold down bolts extend upward beyond the spring plate surface. These hold down bolts secure the spring package to the body. They should be loosened, removed and set aside for reinstallation. Once the screws or hold down bolts are removed, the entire spring package may be lifted from the vent housing. The unit is designed so that a replacement spring package assembly may be installed in the vent housing if disassembly of the original spring package is required.
- Visually inspect the spring package assembly and remove any dirt or residue accumulations. Inspect the gasket located between the housing and the bottom of the spring package. If this gasket is deteriorated it should be replaced.

Warning: If it is necessary to disassemble the spring package, extreme caution must be exercised due to the high spring forces that may be present within the spring package assembly.

SPRING PACKAGE DISASSEMBLY

Note: Measure the compressed height of the largest diameter spring in the spring package and record this information for later use.

- Disassembly of the spring package itself should only be attempted in a work shop or some other controlled environment. High spring forces may be encountered and some provision for controlled retention of the spring package components during the slow release of the spring forces by expansion of the spring(s) must be provided. In most instances, the spring(s) will be compressed to approximately one half of their free length and some clamping means that is able to open within this range to continually counteract the force as the spring is allowed expand to its free length must be provided. A threaded ram utility press with sufficient travel is one example of equipment that may be used to accomplish this task.
- Once the spring package is safely clamped, the stud nuts that hold the spring plate in opposition to the spring force may be loosened and removed. The spring plate can then be allowed to slowly lift until the spring(s) reach their free length. Remove the spring plate, springs, adjusting screw and adjusting plate from the package. Remove the spring package pallet assembly and inspect the diaphragm. If the diaphragm is deteriorated it should be replaced.
- Inspect the seat surface of the spring package. It should be smooth and free of dirt or nicks. If necessary, clean the surface with an appropriate cleaner or solvent. Do not use a file or sharp tool that may damage the seat surface.
- Reassemble the spring package in the reverse order to above. Exercise extreme caution when compressing the spring(s) until the stud nuts can be engaged to secure the spring plate. Make sure that the compressed height of the spring is the same as measured in step (1) above. Adjust the spring compressed height as necessary by turning the threaded adjusting screw and secure in position with locking plate.
- Reinstall the gasket and reassembled spring package in the vent housing. Secure spring package to housing with screws (spring loaded pressure) or slotted/hexagon hold down bolts (spring loaded vacuum).
- Replace cover and hood and secure with wing nuts.