

CAUTION:

If any questions arise concerning the proper installation or maintenance of our products, please contact Protectoseal or one of our Authorized Representatives.

When installing any Protectoseal device, the legal, corporate and advisory safety regulations and procedures appropriate for the specific installation site must be fully understood and followed.

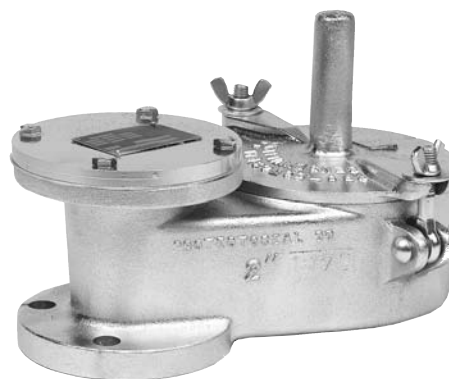

NOTE 1: This vent style includes a removable cover.

NOTE 2: The vacuum setting force for this vent is provided by compression of a spring. Depending on the size and set point of the vent high spring forces may be encountered. Caution must always be exercised when working with the spring packages.

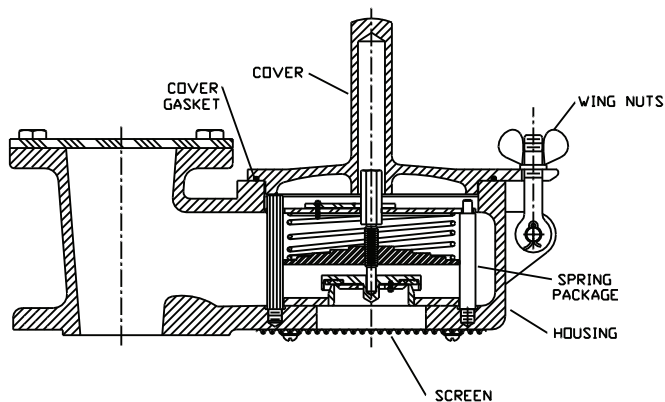

INSTALLATION PROCEDURE:

1. Loosen wing nuts and remove cover.
2. Inspect housing and cover and remove and discard all protective cardboard, tape and flange protectors.
3. Check carefully to insure that all packing materials are removed from on or inside the vent housing.
4. Replace cover and secure with wing nuts. The vent setting is established at the Factory per order specifications. No modifications or adjustments are required prior to vent installation.
5. Mount the vent to the appropriate flanges using gaskets compatible with service conditions. For best performance, the vent should be mounted level so that the seating surfaces are no more than 1° off horizontal.

MAINTENANCE:

Protectoseal recommends that our products be inspected and maintained according to the normal maintenance schedule of the facility. At a minimum, maintenance should be conducted annually. More frequent maintenance may be required, and should be scheduled, for unusual service conditions.

CAUTION: When maintaining any Protectoseal device, the legal, corporate and advisory safety regulations and procedures appropriate for the specific installation site must be fully understood and followed.

CAUTION: Tank vapor space pressure or vacuum should be relieved before any maintenance operations are undertaken.

MAINTENANCE PROCEDURE:

1. Loosen wing nuts and remove cover. No spring forces are involved during cover removal.
2. Inspect the gasket on the cover. Replace if deteriorated or damaged.
3. Remove any loose dirt or foreign material from the housing interior and exterior. Check inside the stem guide hole of the cover and remove any dirt or accumulation of foreign material.
4. This vent is designed to include a modular spring package that may be removed in its entirety from the housing. All spring forces are contained by this Spring Package which can be removed from the housing for inspection or maintenance.

The top of the spring package is the spring plate which is visible below the cover opening in the body. Depending on the size of the vent, four or eight slotted or hexagonal shaped hold down bolts extend upward beyond the spring plate surface. These hold down bolts should be loosened, removed and set aside for reinstallation. Once the hold down bolts are removed, the entire spring package may be lifted from the vent housing. The unit is designed so that a replacement spring package assembly may be installed in the vent housing if disassembly of the original spring package is required.

5. Visually inspect the spring package assembly and remove any dirt or residue accumulations. Inspect the gasket located between the housing and the bottom of the spring package. If this gasket is deteriorated it should be replaced.
6. Inspect vent screen and replace if deteriorated.

Warning: If it is necessary to disassemble the spring package, extreme caution must be exercised due to the high spring forces that may be present within the Spring Package assembly.

SPRING PACKAGE DISASSEMBLY

Note: Measure the compressed height of the largest diameter spring in the spring package and record this information for later use.

1. Disassembly of the spring package itself should only be attempted in a work shop or some other controlled environment. High spring forces may be encountered and some provision for controlled retention of the spring package components during the slow release of the spring forces by expansion of the spring(s) must be provided. In most instances, the spring(s) will be compressed to approximately one half of their free length and some clamping means that is able to open within this

range to continually counteract the force as the spring is allowed expand to its free length must be provided. A threaded ram utility press with sufficient travel is one example of equipment that may be used to accomplish this task.

2. Once the spring package is safely clamped, the stud nuts that hold the spring plate in opposition to the spring force may be loosened and removed. The spring plate can then be allowed to slowly lift until the spring(s) reach their free length. Remove the spring plate, springs, adjusting screw and adjusting plate from the package. Remove the spring package pallet assembly and inspect the diaphragm. If the diaphragm is deteriorated it should be replaced.
3. Inspect the seat surface of the spring package. It should be smooth and free of dirt or nicks. If necessary, clean the surface with an appropriate cleaner or solvent. Do not use a file or sharp tool that may damage the seat surface.
4. Reassemble the spring package in the reverse order to above. Exercise extreme caution when compressing the spring(s) until the stud nuts can be engaged to secure the spring plate. Make sure that the compressed height of the spring is the same as measured in step (1) above. Adjust the spring compressed height as necessary by turning the threaded adjusting screw and secure in position with locking plate.
5. Reinstall the gasket and reassembled spring package in the vent housing. Secure spring package to housing with hexagon hold down bolts.
6. Replace cover and secure with wing nuts.

ADDITIONAL PRODUCTS FROM PROTECTOSEAL

Series 18540



Pipe-Away Pressure Vacuum Relief Vent for applications that require hazardous vapors be processed into manifolded piping and not released into the atmosphere

Series 7800



Emergency Vent protects tanks against rupture or explosion resulting from excessive internal pressure caused by exposure to fires.

Series 4950



Vent Line / In-Line Parallel Plate Flame Arrester is designed for installation in open vent pipe or bleed lines from storage or processing tanks. Suitable for NEC Group D (IEC Group IIA) vapors

Series 830



Combination Pressure / Vacuum Relief Vent & Flame Arrester provides pressure and vacuum relief as well as protection from propagation of externally introduced flames. Suitable for NEC Group D (IEC Group IIA) vapors.