

**CAUTION:**

If any questions arise concerning the proper installation or maintenance of our products, please contact Protectoseal or one of our Authorized Representatives.

When installing any Protectoseal device, the legal, corporate and advisory safety regulations and procedures appropriate for the specific installation site must be fully understood and followed.



**Note 1:** This Vent style includes a removable weatherhood.

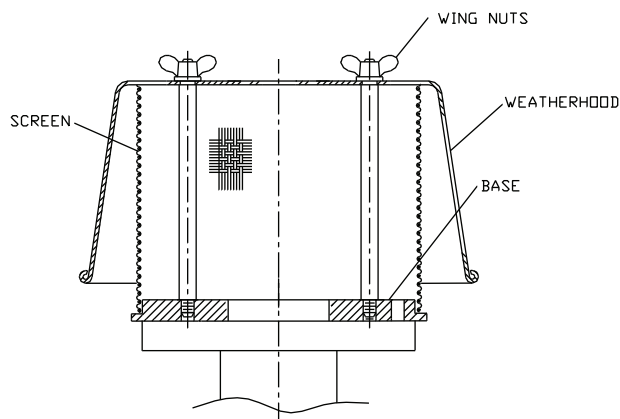

**INSTALLATION PROCEDURE:**

1. Loosen wing nuts and remove weatherhood.
2. Remove and discard all protective cardboard and tape.
3. Remove protective flange cover.
4. Check carefully to insure that all packing materials are removed from on or inside the vent housing.
5. Mount the vent to the appropriate tank flange using gaskets compatible with service conditions. Note: For some vent styles, threaded studs that mate with tapped holes in the vent housing flange are provided.
6. Make sure screen is in place. Replace the weatherhood and secure with wing nuts

**MAINTENANCE:**

Protectoseal recommends that our products be inspected and maintained according to the normal maintenance schedule of the facility. At a minimum, maintenance should be conducted annually. More frequent maintenance may be required, and should be scheduled, for unusual service conditions.

**CAUTION: When maintaining any Protectoseal device, the legal, corporate and advisory safety regulations and procedures appropriate for the specific installation site must be fully understood and followed.**

**CAUTION: Tank vapor space pressure or vacuum should be relieved before any maintenance operations are undertaken.**

**MAINTENANCE PROCEDURE:**

1. Loosen wing nuts and remove weatherhood.
2. Remove any loose dirt or foreign material from the housing interior and exterior.
3. Inspect the screen. Clean or replace as necessary.
4. Replace the weatherhood and secure with wing nuts.