

**CAUTION:**

If any questions arise concerning the proper installation or maintenance of our products, please contact Protectoseal or one of our Authorized Representatives.

When installing any Protectoseal device, the legal, corporate and advisory safety regulations and procedures appropriate for the specific installation site must be fully understood and followed.



**Flanged Type**

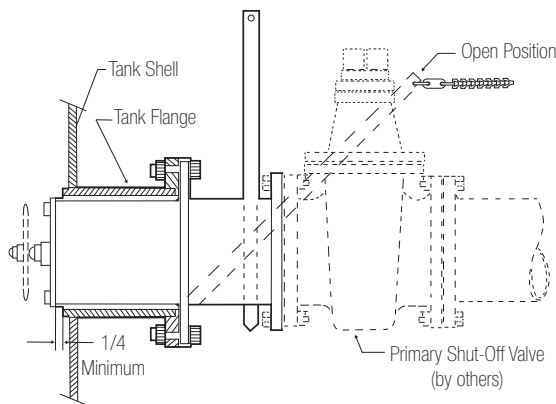

**Threaded Type**

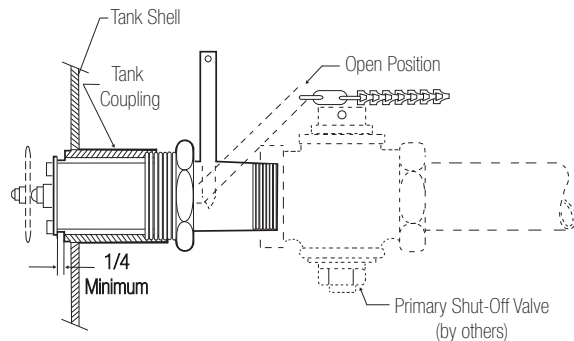

**INSTALLATION PROCEDURE:**

1. Remove all packing material from unit.
2. As received, the valve seat disc should be in the closed position and the operating handle should be at right angles to the axis of the valve. Place the valve in a secure position with the valve handle pointing vertically up and operate the valve mechanism by pulling the handle toward the valve outlet (away from valve seat). If operating properly, the valve seat disc should open approximately 1/3 the I.D. of the valve. When the valve handle reaches the stop position it should be at an approximate 45 degree angle to the valve body. The valve should close automatically when the valve handle is released.

3. Install the internal safety valve in the tank opening using suitable gasket and bolts for flanged versions (tighten bolts diagonally) or suitable pipe sealant for threaded versions. For easy visual checking, the valve should be oriented so that the valve handle is in the vertical up position (see line drawings). However, the internal safety valve will operate properly with the handle in any other position.
4. Check chain attached to handle to see that it is equipped with a fusible link, Protectoseal Part No. 278-M.P. 160°F (71°C).
5. Install positive shut-off valve directly to outlet of internal safety valve. Complete downstream piping.
6. Open the internal safety valve fully and determine the best nearby downstream location for an eyebolt to be installed for permanent hookup of the operating handle chain. The chain may be shortened to accommodate the most convenient location for mounting eyebolt or any already existing eyebolt or "hook-on" device. Close the internal safety valve.
7. Pull handle slightly to crack pilot valve (built-in by-pass valve) to equalize pressure downstream of valve seat disc with the liquid pressure inside the tank. The internal safety valve is now ready to be opened.
8. Open the internal safety valve and lock in open position with fusible link chain (refer to Step 6).
9. Open downstream positive shut-off valve when ready to place installation into full operation.

## MAINTENANCE:

Protectoseal recommends that our products be inspected and maintained according to the normal maintenance schedule of the facility. At a minimum, maintenance should be conducted annually. More frequent maintenance may be required, and should be scheduled, for unusual service conditions.

**CAUTION: When maintaining any Protectoseal device, the legal, corporate and advisory safety regulations and procedures appropriate for the specific installation site must be fully understood and followed.**

**CAUTION: Tank vapor space pressure or vacuum should be relieved before any maintenance operations are undertaken.**

## MAINTENANCE PROCEDURE:

1. Disconnect fusible link chain. The valve should automatically return to the closed (vertically up position). If not, operate the valve handle manually several times until valve operates satisfactorily.
2. If the valve handle does not freely and automatically return to the vertical up position after Step 1 assume that the valve seat disc has been blocked open by foreign material lodged so securely that neither the flow of liquid pumped in and/or out of tank or handle manipulation can dislodge it. The tank should be pumped dry at earliest opportunity to remove the valve so as to manually remove the obstruction. Reinstall the internal safety valve as detailed in the installation instructions on the previous page.

**NOTE:** Steps 3 and 4 refer to Illustration 1 to the right.

3. If leakage past the valve stem is evident, loosen locknut (1) and tighten packing gland (2). Do not over tighten. Operate valve handle (4) manually to make sure it can freely return to the closed position. Tighten locknut (1). Recheck for leakage. If none, reopen the valve and reconnect the fusible link chain (it should not be necessary to wait for pressure equalization).
4. If the valve continues to leak after step #2, the packing should be replaced (available from factory). It is not necessary to remove the internal safety valve from the tank to replace packing. However, the internal safety valve should be in the closed position and the downstream positive shut-off valve should be closed to isolate the valve mechanism. Remove locknut (1), packing gland (2) and packing (3). A small amount of liquid may leak out during removal of the locknut, packing gland and packing. Replace the packing and reinstall the packing gland and locknut and tighten as per preceding instruction. Open the internal safety valve and proceed with installation instructions Steps 7, 8 and 9.

### Illustration 1

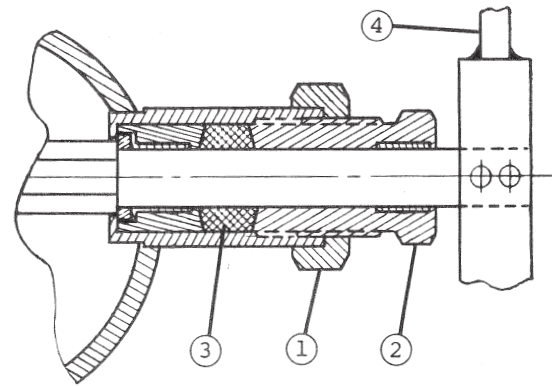

### Illustration 2

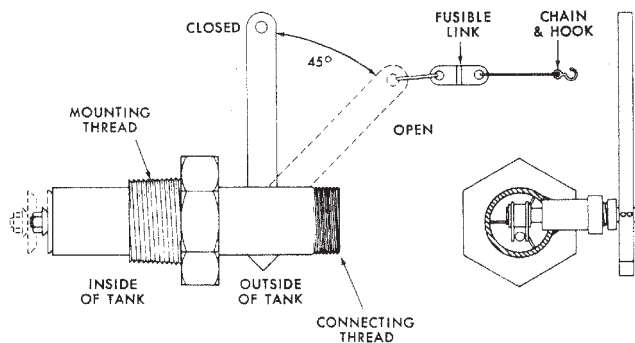

### THREADED TYPE

### Illustration 3

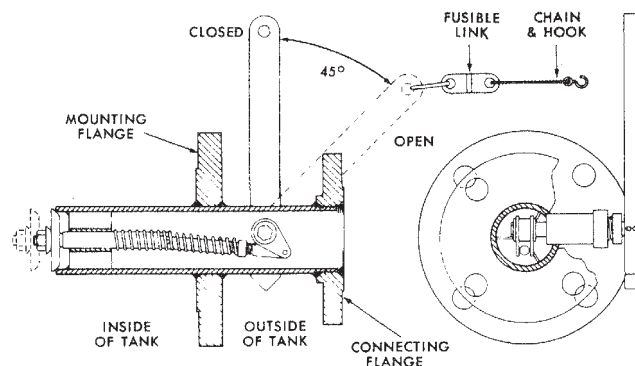

### FLANGED TYPE